

MK 500 INSTALLATION INSTRUCTIONS

CAUTION

1. Locate and identify all parts using hardware lists and the drawings.
2. Heaving items should be hoisted up to the work area using appropriate machinery, ie. hoisting lifts, block and tackle, etc.
3. Make sure MK 500 Beam Mounting Kit and motors/spools are securely attached, and all bolts are properly tightened before testing operation.
4. Keep area below cleared of people during installation, testing and initial operation.

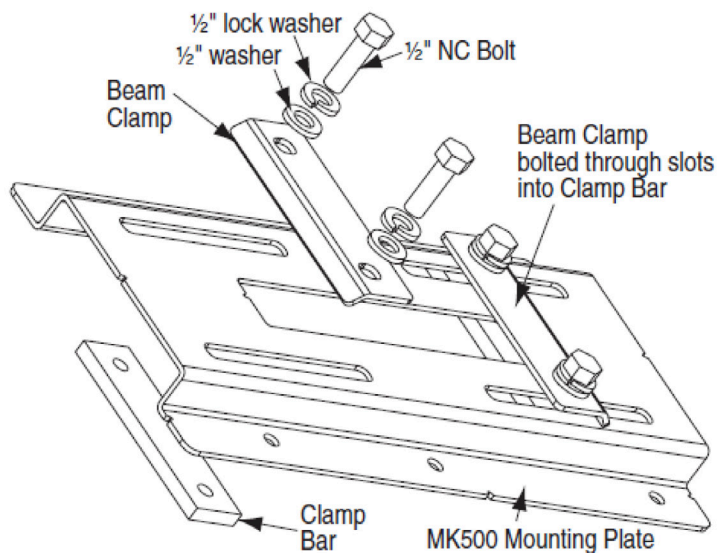

Dimensions

MK500 Beam Mount

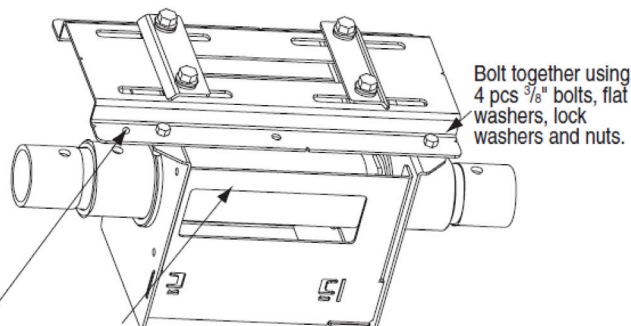
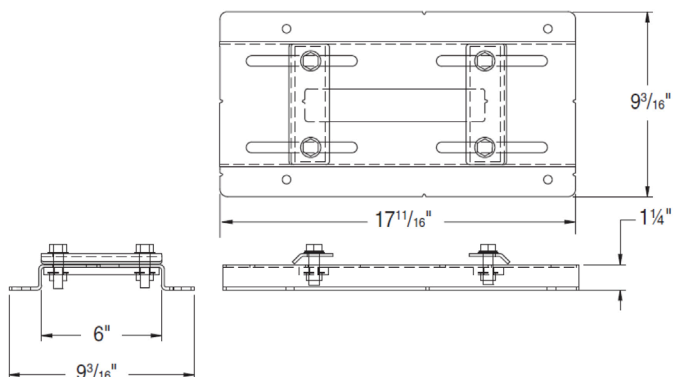

Note how this end overhangs, when viewed from rope window side.
(This centers the rope drum under the beam that the unit is mounted to.)

